



2-030-R
MR16 - Remodel Housing

SPECIFICATIONS

Housing:

- Rated Non I/C.
- Unique clip design, accommodates ceiling thicknesses up to 1 1/2". Housing Can is 18ga. spun aluminum with powder coat paint finish.
- Approved for all ceiling types including air-handling plenums.

J-box:

- 18ga galvanized steel
- 3 K.O. around j-box to allow for easy wire entry
- Approved for branch circuit wiring.

Thermal Protection:

- All Remodel housings have overload protection for over lamping.

Transformer:

- Housings with standard magnetic transformers are rated to MAX 50 Watts. Magnetic core and coil transformers are made with copper windings, Class H Rating (180°C): 120V, 277V, 347V Primary available.
- Optional Electronic transformer housings are available, MAX 50 Watts: 120V, 277V, Primary available only.

Socket:

- Low Voltage MR-16, 12V, (lamp by others).
- Porcelain Bi-Pin socket type GX5.3

Guarantee:

- 5 Year Warranty

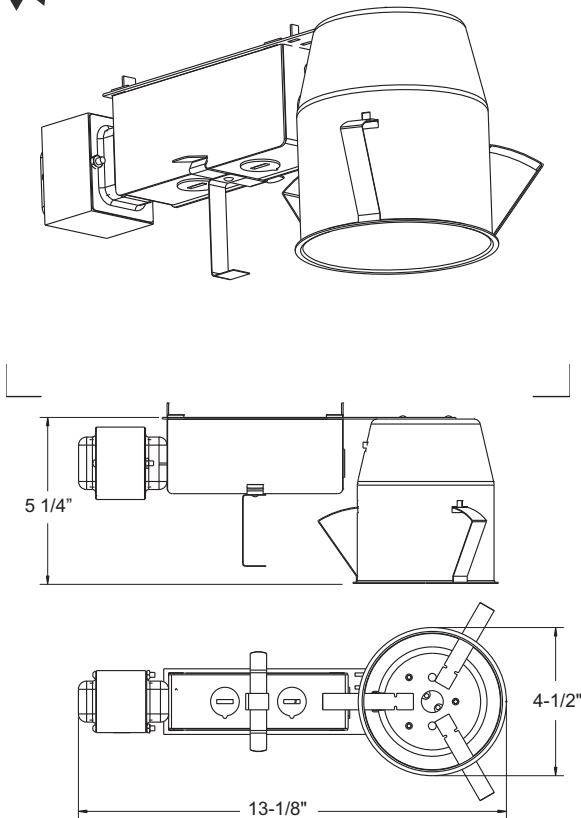

ORDER GUIDE

HOUSING	TRANSFORMER	VOLTAGE
2-030-R	Blank - Magnetic XMR	120
	E - Electronic XMR	277
		347 ¹

Note:
1) Standard magnetic transformer only available.

Trims to be used with 2-030-R	
Aqua	Lensed Picolo
Aurora	Picolo
Deep Aurora	Pin Hole
Conus	Pivot
Coral	Siris
Demi	Split
Eclipse	Slice
Flare Wall Wash	Sunburst
Key Hole	Star Lite

See individual specification sheets for trim details

DaSal Industries Ltd.
Unit #804-1515 Broadway Street
Port Coquitlam, BC V3C 6M2
Phone (604) 464-5644 Fax (604) 464-0888
www.dasalindustries.com

Data and specifications subject to change without notice

Type	Project Name
	Order Number

